

NFPA 58 stipulates that LP-Gas containers and systems must be protected from damage from vehicles (section 6.6.1.2). The specifics to comply with this provision are beyond the scope of NFPA 58 and are covered instead in the International Fire Code in section 312 Vehicle Impact Protection.

Crash Posts installed with the following requirements satisfy this provision*:

- 1.) The posts must be constructed of steel not less than 4" in diameter and must be filled with concrete.
- 2.) The posts must be spaced not more than 4 feet on center.
- 3.) The posts must be set not less than 3 feet deep in a concrete footing of not less than 15 inches in diameter.
- 4.) The top of the posts must be at least 3 feet above the ground.
- 5.) The posts must be set not less than 3 feet from the protected object.

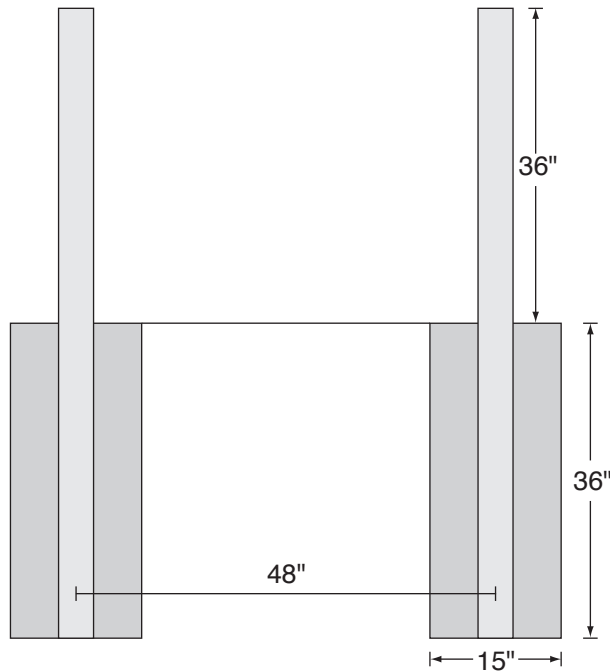

*Note: Other physical barriers can be utilized if the provisions of UFC 312.3 are met.

881 HERSEY STREET ST. PAUL, MN 55114

**PHONE (651) 646-1177
FAX (651) 646-1676**



**IN MINNESOTA 1-800-652-9072
OUT-OF-STATE 1-800-328-9222**